

AIRSOFT NATION

Shooting Competition

Course Design: Evike.com

Rules: Evike Shooting Series Rules, Latest Edition



EVIKE.COM
CLASSIFIER 001
GBB PISTOL - AEG RIFLE

STARTING POSITION Standing inside the Start Box, heels anywhere on the rear fault line. Pistol is placed in middle of table. Rifle is placed to the right side of the table, trigger guard inside the edge of the table top, all Airsoft firearms loaded to division capacity, safeties engaged.

STAGE PROCEDURE Upon Start Signal, retrieve Pistol from table and move to Box 'A' only to engage Pistol Targets. Targets may be engaged in any order. After Pistol Targets are down, move back to the Start Box, retrieve Rifle from table, move to Box 'B' only to engage rifle targets. Targets may be engaged in any order, except for the last target, standing individually (This target ends the timed round). ONE 130rd midcap magazine for rifle and ONE double-stack (Hi-Capa) pistol magazine to be used. **NO RELOADING ALLOWED.**

ABANDONING CONDITIONS Pistol must be returned to center of table, safety engaged or empty chamber. Rifle must be returned to table, safety engaged or empty chamber at Classifier stop.

PISTOL TARGETS 6 Blue ePopper Can (To be engaged from Box 'A')

RIFLE TARGETS 6 Red ePopper Can, 1 Green ePopper Can (To be engaged from Box 'B')

SCORING: Time plus penalties

TARGETS: 6 r-can, 6 b-can, 1 g-can

SCORED HITS: Targets fall and reset

START - Audible **STOP** - Last Shot

PENALTIES Procedural - 10sec.

Procedurals include but not limited to: Engaging stop target early. Engaging targets with the wrong gun, 1 procedural (NOT per shot fired)

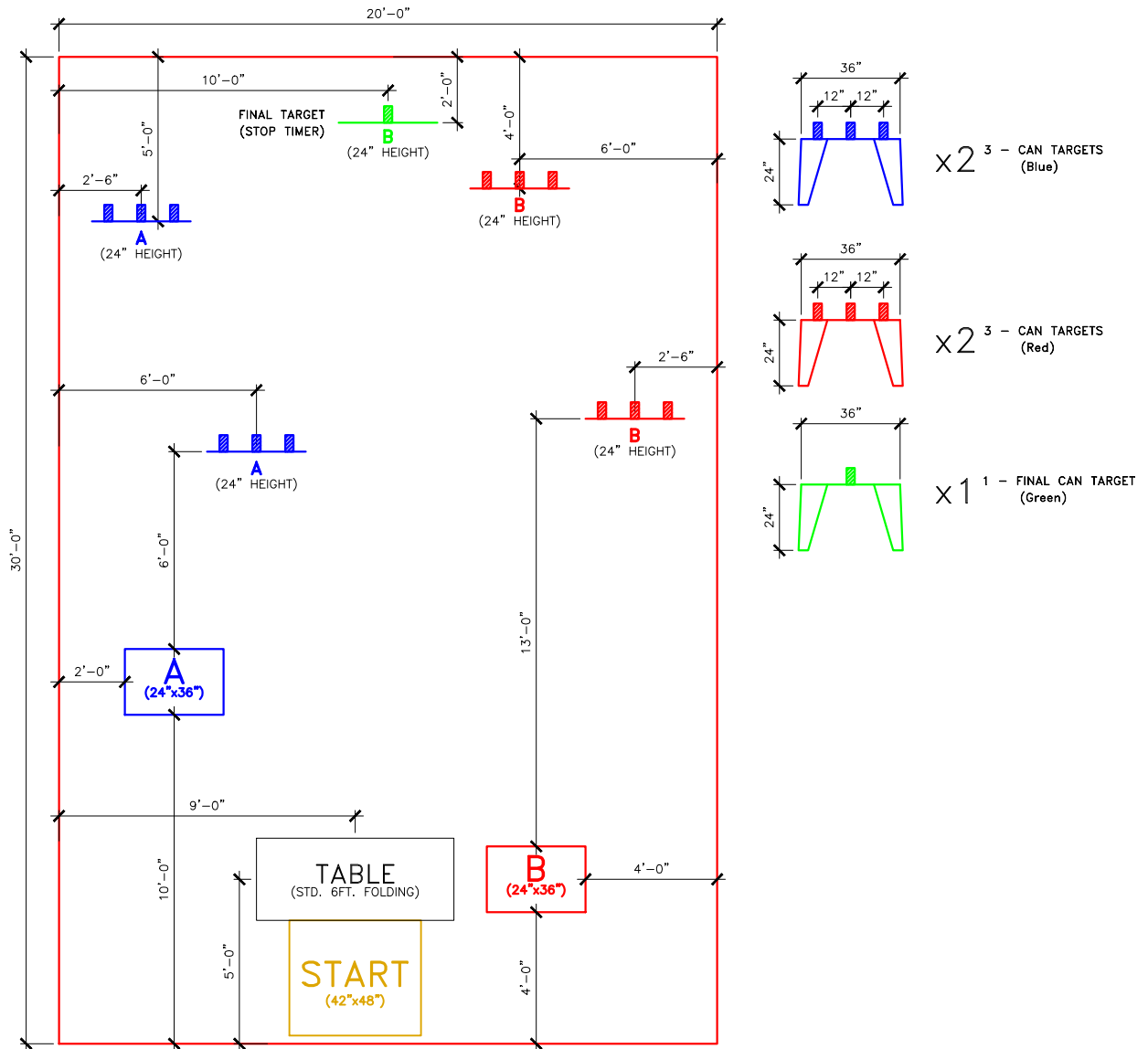

Setup Notes: All Measurements in feet - inches.
Minimum Bay Size: 30ft Deep x 20ft Wide
All target placement measurements to center of targets / stands
Front targets height 24in. Rear targets height 24in.
Face all targets towards shooting boxes.
Table: 6'x2'x30" tall (with un-obstructed underside view)

RO Note: Foot Faults while prone will not incur penalties